

Circles and Specialty Shape Accordia™ Cellular Shades

Thank you for making Levolor a part of your home. You have chosen the finest cellular shades available, backed by the world renowned Levolor name. Learn more about Levolor and discover a resource of information, ideas, and support at www.levolor.com.

Read all installation instructions before installing.

LEVOLOR®

! DANGER STRANGULATION HAZARD

- Keep cords out of the reach of children.
- Move cribs and furniture away from cords.
- Remove objects below windows.
- Loops will appear when the shade is in the raised position.
- Do not tie cords together.
- Install a cord tensioner or cord cleat.



EMERGENCY FIRST AID FOR STRANGULATION.



- Remove cord from child's neck
- Call 911 or Emergency Center
- Clear throat
- Check breathing and heart beat
- Begin CPR

Contacting Us

To contact Levolor customer service regarding any questions or concerns you may have about your new shades, you may reach us at:

1-800-LEVOLOR (9:00 am – 6:00 pm EST)

www.levolor.com

Additional Parts and Services

- **Purchasing extra or replacement parts**
Should the need arise, you may have your Levolor shades repaired or restrung through our repair center. Please contact Levolor customer service through www.levolor.com for a return authorization number.

Important Information

Please read the Window Covering Manufacturers Association, Inc. warning included in these instructions, on the tag attached to the lift cords and on the permanent label on the bottom rail of your shade. Do not remove the permanent label. This assures that future owners of this product will be aware of potential dangers associated with shade cords and children.

Tools you may need (not included)

Tools typically used for installation include:

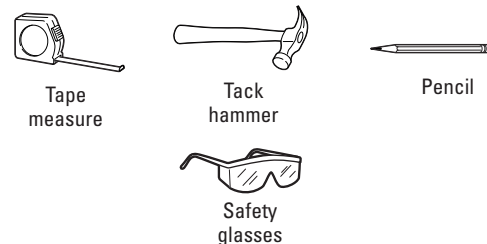

Before you begin your installation:

Read all installation instructions before you begin!

- Make sure that you have all tools and hardware needed for installation.
- Check the installation surface (wall, ceiling, or window frame) to ensure that you have suitable fasteners and tools for the material.
- Check the installation surface (wall, ceiling, or window frame) to ensure that you have suitable fasteners and tools for the material.

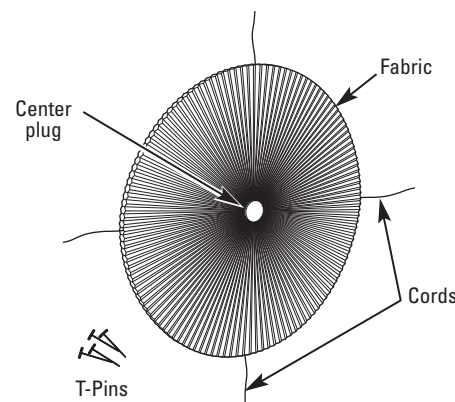

IMPORTANT:

The four cords on your shade do not operate the shade. They are used to suspend the shade within a circular window, and are needed for final installation.

Do not remove them from the shade. If any of the cords fall out, simply fan the shade open and thread the cord(s) through the cells at an equal distance from each other.

1 Expand the shade

- The fabric is cut to the proper length, with double-sided tape preinstalled on one end. Remove the backing from the double-sided tape.

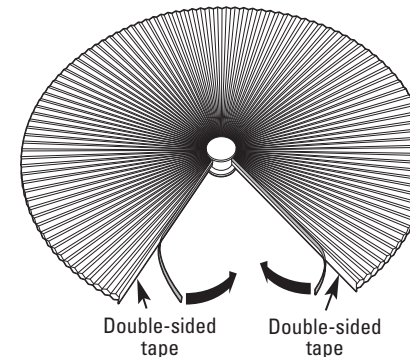

- Being careful not to trap the strings in the tape, fan the shade open around the center plug to form a circle. Press the ends firmly together.

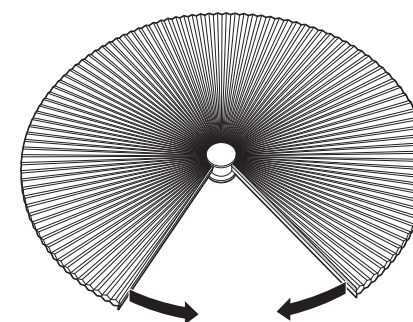

Mounting Options

Your shade can be installed as either an:

Inside mount (2A)—the entire shade fits inside the window casing, or an

Outside mount (2B)—the shade attaches to the wall around the window.

The mounting type is specified when ordering the shade, and determines where the T-pins are installed.

2A Installing the T-pins—inside mount

- Using the tape measure and pencil, mark mounting locations for the T-pins at the top, bottom, and each side of the window casing. Be sure to space them at an equal distance from each other and from the window.
- Using a tack hammer, attach the T-pins at the marked locations.

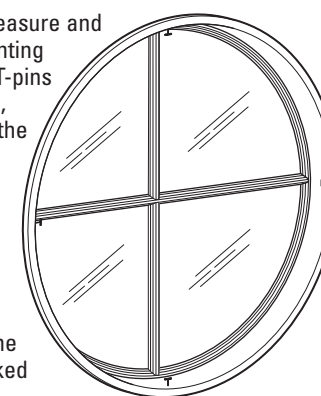

2B Installing the T-pins—outside mount

- Measure the diameter of the shade.
- Using the tape measure and pencil, mark mounting locations for the T-pins at the top, bottom, and each side around the window. Space them evenly around the window at distance slightly smaller than the diameter of the shade.
- Using a tack hammer, attach the T-pins at the marked locations. Once the shade is installed, the pins will be concealed behind the shade.

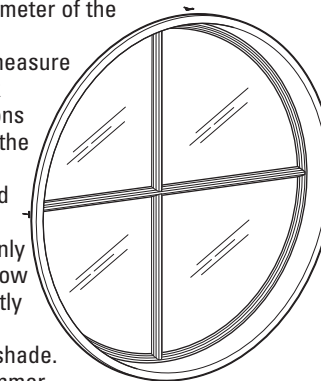

3 Attach the shade to the T-pins

- Position the shade in the window and use the four cords to center it between the T-pins.
- Once the shade is in the desired location, tie the cords to the T-pins.

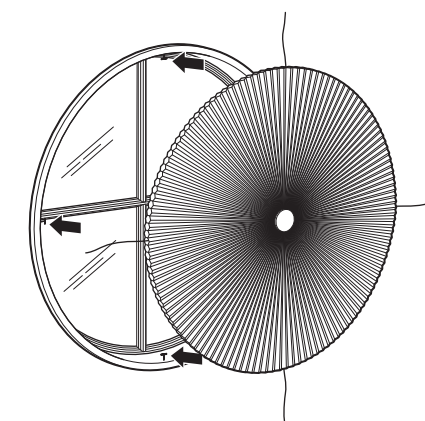

Care and cleaning

- Like any piece of fine furniture, your shade should be dusted regularly. Use a brush-type vacuum attachment or feather duster for dusting; stroke lightly over the shade.
- To clean with water, use a damp sponge and lightly dab.
- Avoid contact with window cleaning products.
- Do not immerse shade in water.

Warranty:

Please refer to the enclosed pamphlet for warranty information.

NOTE: A sales receipt is required for all claims.